

VICINITY MAP
SCALE: 1" = 1000'

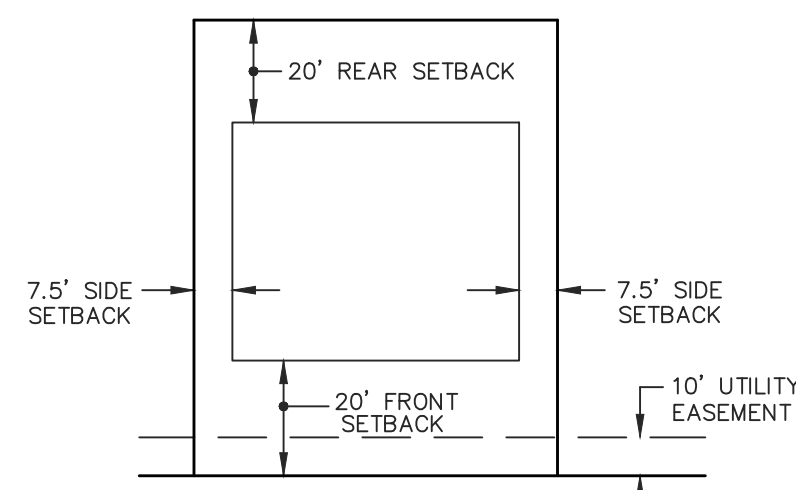

TYPICAL LOT DETAIL

NOTE: 15' MINIMUM DISTANCE BETWEEN BUILDINGS.
REFERENCE COVENANTS FOR LOT SPECIFIC SETBACKS

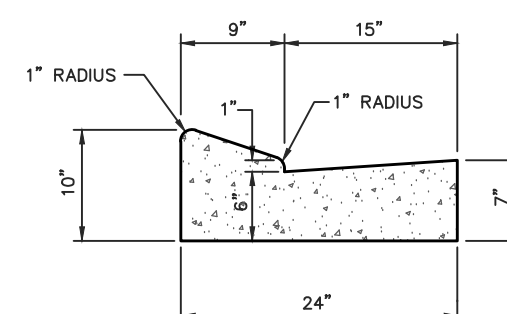

CURB & GUTTER DETAIL

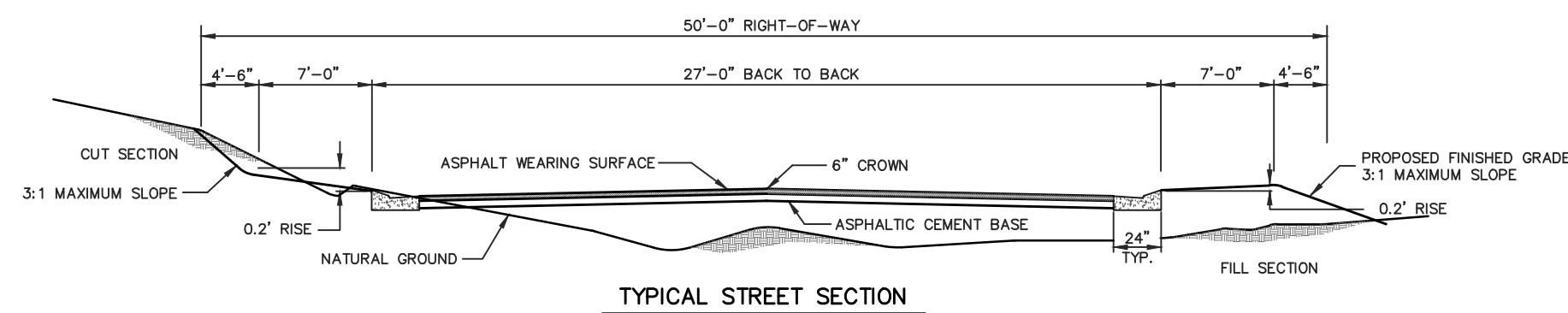

TYPICAL STREET SECTION

CENTERLINE CURVE DATA

① Δ = 13°21'58"	② Δ = 101°44'09"	③ Δ = 55°32'52"	④ Δ = 59°13'53"
D = 3.43619'	D = 76.39433'	D = 23.10379'	D = 28.64789'
R = 1667.42'	R = 75.00'	R = 285.00'	R = 200.00'
L = 388.96'	L = 133.17'	L = 277.96'	L = 206.757'
⑤ Δ = 55°36'02"	⑥ Δ = 42°23'21"	⑦ Δ = 30°26'01"	⑧ Δ = 83°52'22"
D = 28.64789'	D = 28.64789'	D = 11.45916'	D = 28.64789'
R = 200.00'	R = 200.00'	R = 500.00'	R = 200.00'
L = 194.08'	L = 147.97'	L = 265.58'	L = 292.77'

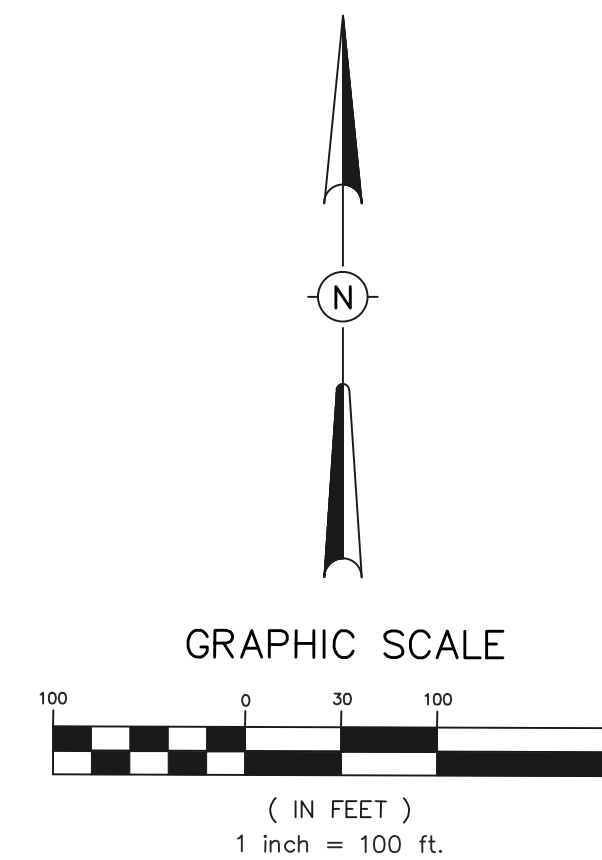

BOUNDARY CURVE DATA

① Δ = 27°22'54"	② Δ = 00°59'01"	③ Δ = 62°26'00"	④ Δ = 40°41'06"
D = 3.89127'	D = 0.45410'	D = 20.28600'	D = 16.51175'
R = 1432.42'	R = 12917.30'	R = 282.44'	R = 247.00'
L = 703.67'	L = 216.61'	L = 307.77'	L = 246.40'
⑤ Δ = 97°54'08"	⑥ Δ = 25°59'01"	⑦ Δ = 23°30'00"	⑧ Δ = 25°59'01"
D = 25.69317'	D = 25.69317'	D = 25.69317'	D = 25.69317'
R = 233.00'	R = 233.00'	R = 233.00'	R = 233.00'
L = 381.04'	L = 381.04'	L = 381.04'	L = 381.04'

- NOTES:
1. THIS SUBDIVISION LIES WITHIN THE LIMITS ESTABLISHED FOR ZONE "X" (NO SHADING) ACCORDING TO FIRM MAP NUMBER: 28089C0395 F, EFFECTIVE MARCH 17, 2010.
 2. DIMENSIONS ALONG CURVES ARE CHORD DISTANCES.
 3. AREA = 35.86 ACRES +/-
 4. CONCRETE MONUMENTS WILL BE PLACED AT ALL CORNERS OF THE SUBDIVISION POST-CONSTRUCTION.
 5. COMMON AREAS AND EASEMENTS SHALL BE MAINTAINED BY THE HOME OWNERS ASSN. OR ADJACENT LOT OWNER, WHICHEVER IS APPLICABLE AS OUTLINED IN THE COVENANTS.
 6. DATE OF FIELD SURVEY: 03-19-21
 7. CONTOURS SHOWN ARE FROM LIDAR IMAGING. (NAVD 88 DATUM).
 8. CURB RETURN RADII IS 20' EXCEPT FOR THE TIE-INS ALONG BRIDGE WATER DRIVE AND PEMBROKE CIRCLE, WHICH IS 30'.

DEVELOPER
MILLBRIDGE, LLC
607 HIGHLAND COLONY PARKWAY, SUITE 200
RIDGELAND, MISSISSIPPI 39157

H D LANG AND ASSOCIATES, INC.
POST OFFICE BOX 16085 JACKSON, MISSISSIPPI 39236
601-362-4886

PROJECT
PRELIMINARY PLAT OF MILLBRIDGE OF CAROLINE

DESCRIPTION
SITUATED IN THE SOUTH 1/2 OF THE SOUTHWEST 1/4 AND THE SOUTHEAST 1/4 OF THE NORTHWEST 1/4 OF SECTION 1, TOWNSHIP 8 NORTH - RANGE 1 EAST MADISON COUNTY, MISSISSIPPI

DATE	REVISION	BY	DRAWN BY: D.L.M.
09-17-24	UPDATE	JBH	DATE: 5-3-22
			SCALE: 1" = 100'
			PROJECT NO.: 00-199

DRAWING NO.